

ISO 9979/0003  
0013

- a) ISO Entry Name { ISO standard 9979 misty1 (13) }
- b) Proprietary Entry Name MISTY1
- c) Intended Range of Applications
1. Confidentiality
  2. Authentication - as detailed in ISO/IEC9798-2
  3. Data Integrity - as detailed in ISO/IEC9797
  4. Hash Function - as detailed in ISO/IEC10118-2
- d) Cryptographic Interface Parameters
1. Input size - 64bits
  2. Output size - 64bits
  3. Key length - 128bits
  4. Round number - a multiple of four
- e) Test Data
1. Round number : 8
  2. Key : 0011 2233 4455 6677 8899 aabb ccdd eeff
  3. Input data : 0123 4567 89ab cdef
  4. Output data : 8b1d a5f5 6ab3 d07c
- f) The Identity of the Organization
- Sponsoring Authority :  
Information-Technology Promotion Agency,  
Japan (IPA)  
Shuwashibakoen 3-chome Bldg. 6F  
3-1-38 Shibakoen, Minato-ku, Tokyo 105, Japan  
Phone +81-3-3437-2301  
Fax +81-3-3437-2537
- Registration Requested by :  
Mitsubishi Electric Corporation
- Contact for Information :  
Secretariat for MISTY Registration  
Information Security Dept.  
Information Technology R&D Center  
Mitsubishi Electric Corporation  
5-1-1 Ofuna, Kamakura, Kanagawa 247, Japan  
Phone +81-467-41-2181  
Fax +81-467-41-2138  
E-mail misty@iss.isl.melco.co.jp
- g) Dates of Registration and Modifications 27 November 1996.
- h) Whether the Subject of a National Standard No
- i) Patent License Restriction The following patent has been applied for:  
PCT/JP96/02154
- j) References See ISO8372 or ISO/IEC10116 for its information on mode of operation.
- k) Description of Algorithm The details of the MISTY1 algorithm are attached in the Appendix.
- l) Modes of Operation Modes of Operation as defined in ISO8372 or ISO/IEC10116 are applicable :
1. Electronic Codebook (ECB) mode
  2. Cipher Block Chaining (CBC) mode
  3. Cipher Feedback (CFB) mode
  4. Output Feedback (OFB) mode
- m) Other Information

# A Description of Block Cipher Algorithm MISTY1

Version 1.10 September 12 1996  
Mitsubishi Electric Corporation

This document shows a complete description of an encryption algorithm MISTY1, which is a secret-key cipher with 64-bit data block and 128-bit secret key. The number of rounds  $n$  of MISTY1 is variable under the condition that  $n$  is a multiple of four.

## Data Randomizing Part

- Figure 1 shows the data randomizing part of MISTY1. The plaintext is divided into two 32-bit data, which are transformed by bitwise XOR operations denoted by the symbol  $\oplus$  and sub-functions  $FO_i$  ( $1 \leq i \leq n$ ) and  $FL_i$  ( $1 \leq i \leq n+2$ ).  $FO_i$  uses a 64-bit subkey  $KO_i$  and a 48-bit subkey  $KI_i$ .  $FL_i$  uses a 32-bit subkey  $KL_i$ .
- Figure 2 shows the structure of  $FO_i$ . The input is divided into two 16-bit data, which are transformed by bitwise XOR operations denoted by the symbol  $\oplus$  and sub-functions  $FI_{ij}$  ( $1 \leq j \leq 3$ ), where  $KO_{ij}$  ( $1 \leq j \leq 4$ ) and  $KI_{ij}$  ( $1 \leq j \leq 3$ ) are the  $j$ -th (from left) 16-bit data of  $KO_i$  and  $KI_i$ , respectively.
- Figure 3 shows the structure of  $FI_{ij}$ . The input is divided into left 9-bit data and right 7-bit data, which are transformed by bitwise XOR operations denoted by the symbol  $\oplus$  and substitution tables  $S_7$  and  $S_9$ . In the first and third XORs, the 7-bit data is zero-extended to 9 bits, and in the second XOR, the 9-bit data is truncated to 7 bits by discarding its highest two bits.  $KI_{ij1}$  and  $KI_{ij2}$  are left 7-bit data and right 9-bit data of  $KI_{ij}$ , respectively.
- Figure 4 shows the structure of  $FL_i$ . The input is divided into two 16-bit data, which are transformed by bitwise XOR operations denoted by the symbol  $\oplus$ , a bitwise AND operation denoted by the symbol  $\cap$  and a bitwise OR operation denoted by the symbol  $\cup$ , where  $KL_{ij}$  ( $1 \leq j \leq 2$ ) is the  $j$ -th (from left) 16-bit data of  $KL_i$ .
- Tables 1 and 2 show decimal representation of the substitution tables  $S_7$  and  $S_9$ , respectively.

## Key Scheduling Part

- Let  $K_i$  ( $1 \leq i \leq 8$ ) be the  $i$ -th (from left) 16-bit data of the secret key  $K$ , and let  $K'_i$  ( $1 \leq i \leq 8$ ) be the output of  $FI_{ij}$  where the input of  $FI_{ij}$  is  $K_i$  and the key  $KI_{ij}$  is  $K_{i+1}$ . Also, identify  $K_9$  with  $K_1$ .
- The correspondence between the symbols  $KO_{ij}, KI_{ij}, KL_{ij}$  and the actual key is as follows:

Symbol	$KO_{i1}$	$KO_{i2}$	$KO_{i3}$	$KO_{i4}$	$KI_{i1}$	$KI_{i2}$	$KI_{i3}$	$KL_{i1}$	$KL_{i2}$
Key	$K_i$	$K_{i+2}$	$K_{i+7}$	$K_{i+4}$	$K'_{i+5}$	$K'_{i+1}$	$K'_{i+3}$	$K'_{\frac{i+1}{2}}$ (odd $i$ ) $K'_{\frac{i}{2}+2}$ (even $i$ )	$K'_{\frac{i+1}{2}+6}$ (odd $i$ ) $K'_{\frac{i}{2}+4}$ (even $i$ )

where  $K_i$  and  $K'_i$  are identified with  $K_{i-8}$  and  $K'_{i-8}$ , respectively, when  $i$  exceeds 8.

## Test Data

- The following is sample data for MISTY1 with eight rounds in hexadecimal form:

Secret Key ( $K_1$ to $K_8$ )	00 11 22 33 44 55 66 77 88 99 aa bb cc dd ee ff
Plaintext	01 23 45 67 89 ab cd ef
Extended Key ( $K'_1$ to $K'_8$ )	cf 51 8e 7f 5e 29 67 3a cd bc 07 d6 bf 35 5e 11
Ciphertext	8b 1d a5 f5 6a b3 d0 7c

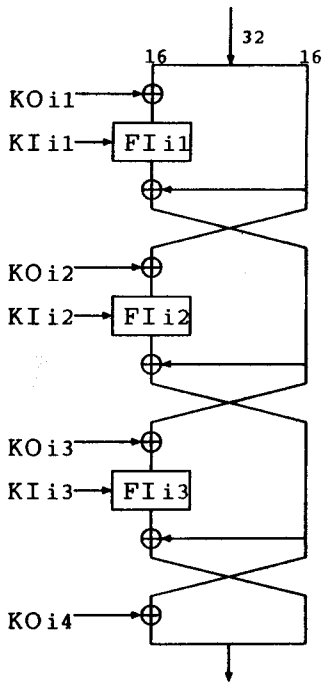

Figure 2: FOI

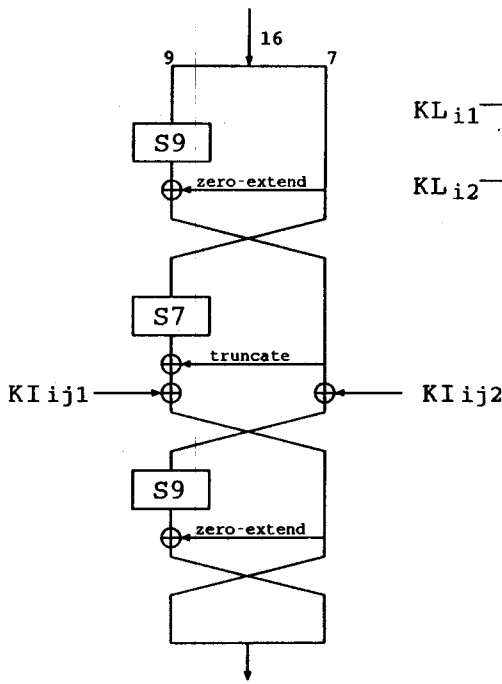

Figure 3: FIij

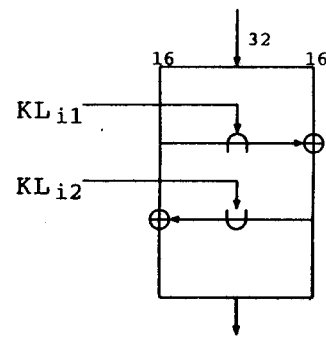

Figure 4: FLi

27, 50, 51, 90, 59, 16, 23, 84, 91, 26,114,115,107, 44,102, 73, 31, 36, 19,108, 55, 46, 63, 74, 93, 15, 64, 86, 37, 81, 28, 4, 11, 70, 32, 13,123, 53, 68, 66, 43, 30, 65, 20, 75,121, 21,111, 14, 85, 9, 54,116, 12,103, 83, 40, 10,126, 56, 2, 7, 96, 41, 25, 18,101, 47, 48, 57, 8,104, 95,120, 42, 76,100, 69,117, 61, 89, 72, 3, 87,124, 79, 98, 60, 29, 33, 94, 39,106,112, 77, 58, 1,109,110, 99, 24,119, 35, 5, 38,118, 0, 49, 45,122,127, 97, 80, 34, 17, 6, 71, 22, 82, 78,113, 62,105, 67, 52, 92, 88,125

Table 1: The table of  $S_7$ .

451,203,339,415,483,233,251, 53,385,185,279,491,307, 9, 45,211,199,330, 55,126,235,356,403,472,163, 286, 85, 44, 29,418,355,280,331,338,466, 15, 43, 48,314,229,273,312,398, 99,227,200,500, 27, 1,157, 248,416,365,499, 28,326,125,209,130,490,387,301,244,414,467,221,482,296,480,236, 89,145, 17,303, 38, 220,176,396,271,503,231,364,182,249,216,337,257,332,259,184,340,299,430, 23,113, 12, 71, 88,127,420, 308,297,132,349,413,434,419, 72,124, 81,458, 35,317,423,357, 59, 66,218,402,206,193,107,159,497,300, 388,250,406,481,361,381, 49,384,266,148,474,390,318,284, 96,373,463,103,281,101,104,153,336, 8, 7, 380,183, 36, 25,222,295,219,228,425, 82,265,144,412,449, 40,435,309,362,374,223,485,392,197,366,478, 433,195,479, 54,238,494,240,147, 73,154,438,105,129,293, 11, 94,180,329,455,372, 62,315,439,142,454, 174, 16,149,495, 78,242,509,133,253,246,160,367,131,138,342,155,316,263,359,152,464,489, 3,510,189, 290,137,210,399, 18, 51,106,322,237,368,283,226,335,344,305,327, 93,275,461,121,353,421,377,158,436, 204, 34,306, 26,232, 4,391,493,407, 57,447,471, 39,395,198,156,208,334,108, 52,498,110,202, 37,186, 401,254, 19,262, 47,429,370,475,192,267,470,245,492,269,118,276,427,117,268,484,345, 84,287, 75,196, 446,247, 41,164, 14,496,119, 77,378,134,139,179,369,191,270,260,151,347,352,360,215,187,102,462,252, 146,453,111, 22, 74,161,313,175,241,400, 10,426,323,379, 86,397,358,212,507,333,404,410,135,504,291, 167,440,321, 60,505,320, 42,341,282,417,408,213,294,431, 97,302,343,476,114,394,170,150,277,239, 69, 123,141,325, 83, 95,376,178, 46, 32,469, 63,457,487,428, 68, 56, 20,177,363,171,181, 90,386,456,468, 24,375,100,207,109,256,409,304,346, 5,288,443,445,224, 79,214,319,452,298, 21, 6,255,411,166, 67, 136, 80,351,488,289,115,382,188,194,201,371,393,501,116,460,486,424,405, 31, 65, 13,442, 50, 61,465, 128,168, 87,441,354,328,217,261, 98,122, 33,511,274,264,448,169,285,432,422,205,243, 92,258, 91,473, 324,502,173,165, 58,459,310,383, 70,225, 30,477,230,311,506,389,140,143, 64,437,190,120, 0,172,272, 350,292, 2,444,162,234,112,508,278,348, 76,450,

Table 2: The table of  $S_9$ .

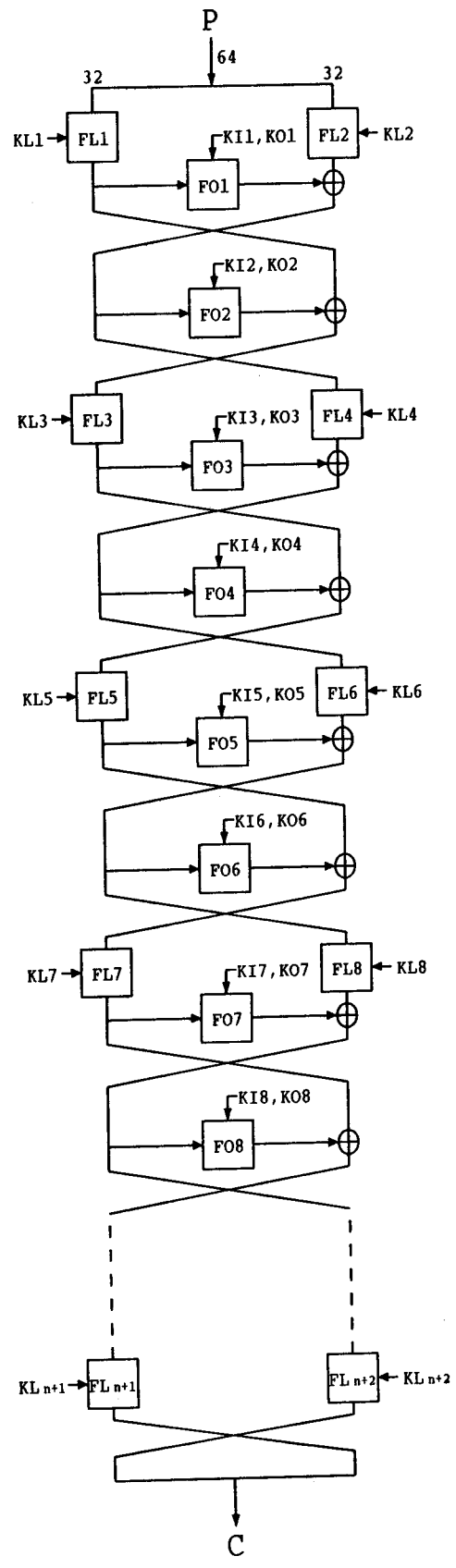

Figure 1: MISTY1